The Colour Sensations in Terms of Luminosity

W. de W. Abney

Phil. Trans. R. Soc. Lond. A 1900 **193**, 259-287

doi: 10.1098/rsta.1900.0008

Email alerting service

Receive free email alerts when new articles cite this article - sign up in the box at the top right-hand corner of the article or click [here](#)

To subscribe to *Phil. Trans. R. Soc. Lond. A* go to: <http://rsta.royalsocietypublishing.org/subscriptions>

VIII. *The Colour Sensations in Terms of Luminosity.**By Captain W. DE W. ABNEY, C.B., D.C.L., F.R.S.*

Received February 23,—Read June 15, 1899.

(I.) *Introductory.*

My attention has been directed recently to the theoretical considerations involved in the production of photographs in approximately the colours of Nature, by combining together the images from three positives backed by appropriate colour screens, the colours chosen being those which should best represent the three Colour Sensations of the Young Theory.

During my investigations into the matter I found it necessary to ascertain what these colours were, for although serious objections may be raised to the Young Theory when considering it in detail, yet when expressed in a general form it adequately explains the phenomena which arise when colours fall upon the centre of the retina. The sensation curves have been given by KÖENIG, but it appeared that a redetermination by a luminosity method might well be undertaken, for they did not altogether agree with the results of some preliminary measures that I had made in order to trace them. In my work on 'Colour Vision' I have given a rough diagram as to what the sensation curves might be when they are shown as luminosities which together make up the total luminosity of the spectrum of the crater of the arc light, but it was only intended to be an approximation to the correct diagram. The method, however, by which the problem could be attacked and by which a rigid determination could be made was indicated. It is by this method that the results given in the following pages have been obtained.

(II.) *A Preliminary Survey.*

The red sensation can be perceived in purity at one end of the spectrum. From the darkest red to a point near the C line, a little above the red lithium line, the colour is the same, though, of course, the brightness varies, but the brighter red colour can be reduced to form an exact match with the dark red, and no mixture of any colours will give a red of the description we find at the end of the spectrum.

At the violet end of the spectrum we also find that the colour is the same throughout, from the extreme visible limit to a point not far removed from G, but it is not for

this reason to be accepted that the colour is due to only one sensation. It might be due to two or three sensations if they were stimulated in the same proportions along that region, and if the identical colour could be produced by the combination of other colours. Experiment shows that a combination of two colours will make violet under certain conditions, and that instead of a simple sensation of violet we have in this region a blue sensation combined with a large proportion of red sensation. The proof of this and the estimation of the percentage composition of the violet will be given subsequently. It may, however, be here stated, that if we know the percentage composition we may provisionally use this part of the spectrum as if it excited but one sensation, and subsequently convert the results obtained with it into the true sensations. Thus in calculating the percentage of red in any colour, that existing in the provisional violet sensation would have to be added to it, and the same amount be abstracted from the violet to arrive at the true blue sensation. The green sensation would remain unaltered. In the first part of this paper the provisional violet sensation will be employed and the necessary corrections subsequently made.

In using the violet it must be recollected that the colour is usually contaminated with the white light which illuminates the prism or grating, and that such illumination may be very appreciable at a part of the spectrum where the luminosity is very small. White light must therefore be cut off as far as practicable, and by use of an absorbing medium such as blue glass coated with a gelatine film dyed with a blue dye this is attained. The use of a second prism in front of the spectrum is inconvenient though effectual.

(III.) *Possible Mixtures of Sensations.*

Having at one end of the spectrum a pure red sensation, and at the other mixed sensations, due to the stimulation of the red and a blue sensation, it remains to isolate the green sensation. Owing to the overlapping of the curves in the green of the spectrum, due to the fact that this region stimulates all three of the sensations, the effect of the pure green sensation is never experienced by a normal eye, though presumably it is by what are termed the red-blind of the Young Theory. In any colour where the stimulation of all three sensations occurs, there must be always an admixture of white light, and we have to search for that point in the spectrum where white alone is added to the green sensation.

The following diagram, fig. 1, will show the variations in composition of a colour that may be met with. The provisional use of a violet sensation will not alter the argument, since, as before said, we may replace it by blue and red sensations. The different figures are purely diagrammatic. They are constructed on the supposition that equal heights of line above the base show the stimulation necessary to give the effect of white light. The scale applicable to each of the three lines is necessarily quite different to the scale of luminosity, that of the violet in particular is very greatly exaggerated. A, B, &c., mean that colours may exist each containing a

sensation of white, the amount being shown by the portions between the horizontal parallel lines. I, II, and III, &c., show colours which are due to the mixtures of two sensations. A and D are the two most interesting colours. If we take away the green sensation from A we have the mixture of red and violet which a green-blind person would match with white. Similarly, if we take away the red sensation from D we have a mixture of green and violet which the red-blind person would match with white.

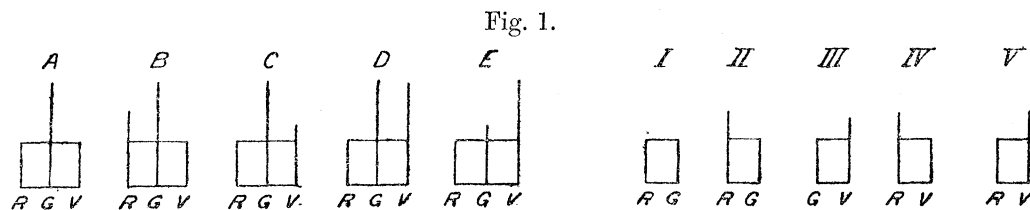

The position which D occupies in the spectrum can readily be found by the normal eye, by finding that colour which, with red alone added, matches the white employed, in other words by finding the complementary colour to the red. The position of A in the spectrum is much less readily determined by the normal eye, since it requires the addition of both red and violet to make the white, a condition which is also necessary with B and C. The position can of course be determined by the aid of the green-blind eye, but a preliminary measurement of colour sensations involving the assumption of its position enables it to be fixed with the required accuracy. Before the measurements herein recorded were made such a preliminary set of observations was gone through, and the position found which was subsequently confirmed by a green-blind person. (See XXII.)

(IV.) *Precautions to be taken.*

There were several considerations that had to be taken into account in making these measures. In the first place, the white light used in the observations had to be of the same quality, that is, the relative luminosities of the different rays of the spectrum had to be constant, for it must not be supposed that the positions in the spectrum of A and D are fixed points except for the same quality of white light. They may be separated from one another by nearly the same interval in the spectrum when different qualities of white light are measured, but the larger the proportion of blue contained in the white the more they will approach the more refrangible end of the spectrum. For instance, the positions will be nearer the red with the white light emitted by the crater of the positive pole of the electric light than they would be with light of the sun on a June day near noon. Again, the final equations, for white light, given in terms of the three sensations will vary according to the white light employed, and they will also vary according to the extent of the area of the retina on which the colour images fall. This last variation is caused by the absorption by the macula lutea, and may differ in different eyes. If,

however, we can express the colours in all parts of the spectrum in *percentages* of luminosity of the three sensations, we can readily convert the equation derived for one quality into that for any other.

Bearing in mind the effect of the retinal area, it will be seen that it is necessary always to compare the patches of mixed colours when of the same size and viewed from the same distance, and with the centre of the retina. The light from the crater of the positive pole of the arc light, being always of the same quality and of great "whiteness," and giving a spectrum which is rich in blue rays, may be conveniently adopted as a standard. Moreover, this white seems to be of the same quality as the white light seen outside the colour fields, thus approaching to the fundamental white sensation.

(V.) *Method of Finding the Value of the Red and Green Sensations.*

It need only be stated that no blue sensation was found from D (sodium line) to the extreme limit of the spectrum in the red, and that in the yellow the amount found is very small compared with that of the red and green sensations. So below D to the red lithium line we have a mixture, in varying proportions, of pure red and green sensations, and from D to the yellow-green the same two sensations, but not absolutely free from the third sensation.

A colour in the spectrum which matches a solution of bichromate of potash will thus only excite the red and green sensations, and if we can find out in what proportions the two exist as luminosities in a given luminosity of the colour, we can readily determine the sensation luminosity composition of any other colours by means of ordinary colour equations expressed as comparative luminosities. To ascertain the composition of such an orange colour was the object of the first part of the investigation.

Turning to II, in fig. 1, we see that we have only to add to the colour it represents such a quantity of properly chosen violet to form white, the red and green sensations being present in the proper proportions. If, therefore, we ascertain the complementary colour to the violet, we shall find the colour which is equivalent to II, and this we find to be in the yellow. Having ascertained the luminosity of the red and green sensations in the orange, and from them the relative luminosities of the same two sensations in the complementary colour to the violet, we at once get in terms of the red, the green, and the (provisional) violet sensations the equation to the white light of the quality we may be using.

(VI.) *Apparatus Employed.*

The colour patch apparatus employed in 'Colour Photometry' was again used (fig. 2). The rays R, R, coming from the crater of the positive pole of the electric light, were collected by a lens, L₁, and an image of the crater thrown on the slit S₁.

After passing through the collimator C , the rays emerged as parallel rays; part passed through the prisms P_1 and P_2 , were collected by a lens, L_3 , and a spectrum was formed on a slide, D (which will be more fully described), in which slits could be placed, and an image of the surface of the first prism was formed on the white-red surface of a cube, E , by means of the lens L_4 , so arranged that the image of one edge of the prism fell at a , the other edge falling outside d . The other beam which passed through the collimator was reflected from the surface of the first prism to a mirror, G^I , and passed

Fig. 2.

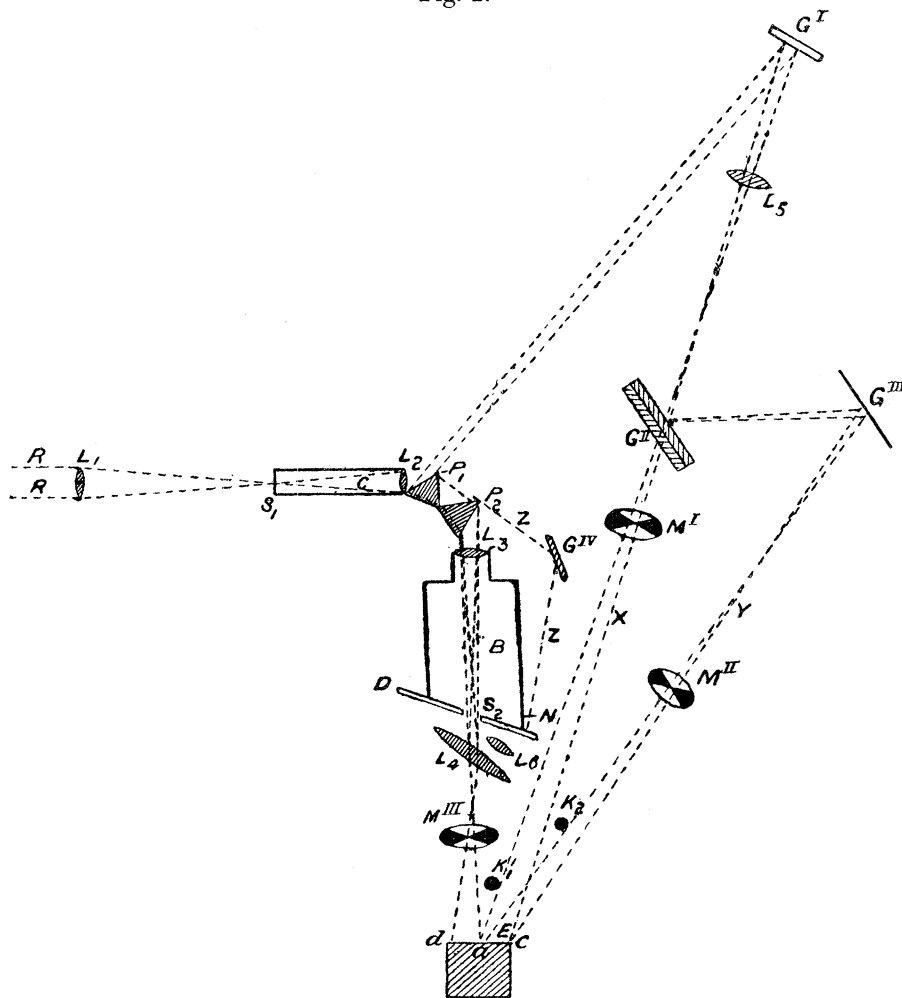

through a lens, L_5 , then through a bundle of glass, G^{II} , placed at an angle to the beam, and on to the surface dc of the cube, a rod, K_1 , being placed in its path, to secure that this white beam did not fall on ad , on which the colour mixture fell. The portion of the beam which was reflected from G^{II} was again reflected by G^{III} , a silvered mirror, on to ac , a rod, K_2 , being placed in its path to prevent it falling on ad . In all three beams, sectors, M^I , M^{II} , and M^{III} , were placed, to allow any or all to be reduced in intensity at pleasure. In the beams X and Y any absorbing medium desired could

be placed. A small ray of light, Z , was allowed to pass beyond P_2 , and fell on a small mirror, G^{IV} , which reflected it on to the back of D , casting a shadow of a needle, N , fixed to B , the camera, on S , a scale at the back of D .

L_6 is a lens of short focus which could be moved into a fixed position behind L_4 to throw an enlarged image of the slit on a scale placed below dc .

In order to form colour mixtures on ad three slits had to be placed along the surface D . The slits were arranged in an open brass frame which slid along the plane D in grooves cut in B . At the bottom and top of the frame or slit holder two pairs of grooves were cut. In the front pair the slits could slide and be clamped in any desired position as determined by a scale engraved along the lower groove, whilst the back pair of grooves was used to hold blackened cards which filled up the intervals between the slits. The position of the slit holder was determined by the shadow cast by the needle N on the scale engraved on its back.

(VII.) *Ascertaining the Position of the Slits in the Spectrum.*

By placing one slit at some fixed number on the front scale and then causing the slit holder to move along the spectrum till known lines (due to metals vaporised in the arc) passed through the centre of the aperture, and there noting the scale number at the back, the position of the slits however placed was known. The position of the principal Fraunhofer lines in regard to the front scale was thus determined when the slit holder was placed in a fixed position as indicated by the needle shadow.

(VIII.) *Method of Determining the Colour Sensations in an Orange Ray of the Spectrum.*

It has already been stated that from a preliminary survey it was found that in the orange no blue sensation was excited, and that only red and green had to be determined. Further, it was stated that A , fig. 1, was a colour where the green sensation existed mixed only with white. If these two slits were placed in the spectrum, one in the pure red which only excited the red sensation, and the other at A , it should be possible to make such a mixture of the two colours that they should match the orange colour to which white in known quantity was added. A cell containing bichromate of potash in solution was placed in the beam X , and one slit in D (fig. 2) was caused to traverse the spectrum till the colours appeared to match. It was found, however, that the bichromate was a little paler than the orange of the spectrum, and the beam Y was diverted so that it fell only on ad . The white was diminished till a match was secured and the luminosities of the two were measured, when it was found that the bichromate colour contained 4.995 per cent. of white as compared with the orange that matched it.

The bichromate solution could now be used to give a colour to be matched. The

slits were placed at Slit Scale Nos. (afterwards designated as SSN) 205 and 288·5 (the latter number having been found by preliminary trials to be A), and a mixture of the two beams fell on *ad*, making as near a match as possible with the colour of the bichromate solution placed in the beam X. To the latter was added white from the beam Z, and by altering the sectors and slits a perfect match could be obtained. This being effected the width of the slits was measured by the method which has been indicated in describing the apparatus. The small lens, L_6 , was pushed in position to the centre of the lens, L_4 , and the slits successively brought into the colour which passed through the centres of these two lenses by sliding the slit holder along the spectrum. A magnified and sharp image in monochromatic light was then thrown on the scale below, *dc*, and the relative width of the apertures noted. This plan obviates recourse to wedges for measuring, and is very convenient. It has been employed by myself for measuring pin holes and other small apertures. The slits having been measured they were replaced in position, and the luminosities measured as has been described in 'Colour Photometry,' Part I.* Other matches were made and the aperture of the slit again measured, but the luminosity not necessarily, as the relation between width of slit and luminosity was determined from the first observations. Had the area of the retina on which the image fell been the same as that employed in 'Colour Photometry,' Part III,† and if the quality of the white had not been slightly changed by the interposition of the bundle of glass, G^{III} , the luminosities might have been taken from the tables in that paper.

The form of the equation then becomes of this kind—

$$m(R) + n(G) = a[(Or) + (w)] + b(W) \dots \dots \dots (i).$$

where R, G, Or, W, and *w* stand for the red, the green, the orange, the added white, and the white in the bichromate solution colour respectively, and *m*, *n*, *a*, *b* constants.

Now as the orange can contain but two sensations, and as the red is a pure sensation and consequently not contaminated with white, it follows that *a(w)* and *b(W)* must be in *nG*, and we get

$$m(R) + [n(G) - a(w) - b(W)] = a(Or) \dots \dots \dots (ii).$$

That is, when the luminosity of the white is deducted from the luminosity of the green we get the green sensation left, and, finally, we get

$$m(RS) + n'(GS) = a(Or), \dots \dots \dots (iii).$$

where RS and GS are the red and green sensations respectively.

* 'Phil. Trans.,' A, 1889.

† *Ibid.*, 1896.

(IX.) *Method of Determining the Red and Green Sensations in the Yellow which is complementary to the Violet.*

We are now in a position to determine the RS and GS, in that yellow is complementary to the violet, which, in this as in the previous case, we are assuming to be a simple sensation. From the preliminary observations we know that the amount of violet in the yellow is very minute, and is for our purpose here negligible. If one slit be placed in this particular yellow and another in the red near the lithium line, and the two colours be mixed to match the spectrum orange, we get

$$p(Y) + q(R) = c(Or) \quad \dots \dots \dots (iv.),$$

where Y signifies the yellow. But

$$m(RS) + n'(GS) = a(Or),$$

therefore

$$\frac{p}{c}(Y) = \left(\frac{m}{a} - \frac{q}{c}\right)(RS) + \frac{n'}{a}(GS) \quad \dots \dots \dots (v.),$$

and we have this particular yellow expressed in terms of the luminosity of the two sensations. Measurements made with a mixture of yellow and violet give the equation

$$r(Y) + t(V) = W \quad \dots \dots \dots (vi.).$$

Substituting from v. we get an equation of the form

$$\alpha(RS) + \beta(GS) + \gamma(V) = 100(W) \quad \dots \dots \dots (vii.),$$

and this becomes the standard equation for the particular white employed.

If we take another green which does not answer to A, fig. 1, we get

$$f(RS) + g(G) + k(V) = 100(W). \quad \dots \dots \dots (viii.).$$

From vii. and viii. we get

$$100(G) = \alpha'(RS) + \beta'(GS) + \gamma'(V),$$

and this is the percentage composition in luminosities of this particular green.

This method applies for every spectrum colour up to that which answers to D, fig. 1, but it is not quite so well adapted for colours which lie on the blue side of this point.

(X.) *Method of Determining the Composition of the Rays in the Blue End of the Spectrum.*

The most ready method of determining the percentage composition of the colours which lie between *b* and the violet, is as follows: a slit is placed in position to allow a blue of a natural wave-length to pass, and a second slit is placed at the SSN which corresponds to the yellow, whose composition is already determined. No mixture of blue and this yellow will make a white corresponding to that we have to compare with it, but the slit-holder can be moved towards the red till a match is made, *i.e.*, where the slightly redder yellow is complementary to the blue which passes through the first slit. The shift of the slit-holder from the fixed point is noted, and from it are calculated the new positions of the two slits. From the previous measures made in the red orange and green portions of the spectrum, the percentage composition in red and green sensation-luminosity is known, and the luminosity of the light coming through the slit in the redder yellow is divided proportionally between these two sensations, and we have an equation of the form

$$\alpha'' (\text{RS}) + \beta'' (\text{GS}) + \gamma'' (\text{B}) = 100 (\text{W}).$$

The standard equation (vii.) is used as before, and we get the blue (B) in terms of the two sensations and the violet.

(XI.) *Method of Determining the Composition of the Violet.*

The last determination that has to be carried out is the composition of the violet. We already know that up to a point near G it is uniform in colour. But if we place a slit in the blue near the blue lithium line, and another in the red near the red lithium line, and endeavour to match the violet, we shall find that although we get a purple, yet it is too pale; a third slit is placed in the violet, and by a right-angled prism the beam is diverted and again deflected to fall on *da*, fig. 2, and the white beam Z is also reflected to fall on the same part of the white surface. The mixture of red and blue falls on *ac*. White is added to the violet till a match is made. The luminosities of all the colours and the white are compared together, and an equation is formed of this form

$$a (\text{V}) + b (\text{W}) = m (\text{B}) + n (\text{R}).$$

Now, as the red contains no white sensation, that shown on the left-hand side of the equation must be found in the blue, a proportion of blue, green and red going to form it. All the green sensation must be "used up" in forming the white, and only the blue sensation and the red sensation can remain beyond the white. We thus get

$$\begin{aligned} a (\text{V}) &= n (\text{RS}) + [m (\text{B}) - b (\text{W})] \\ &= n (\text{RS}) + m' (\text{BS}). \end{aligned}$$

2 M 2

By taking colours on each side of the blue lithium line we find that the proportions of blue and red sensations are unchanged, and always fulfil the above equation.

Having found the percentage composition of all the spectrum in terms of the red and green sensations and of violet, the last is converted into blue sensation and red sensation. The red sensation existing in the violet is then added to that already found.

(XII.) *Difficulties in making the Observations.*

The description of the nature of the observations may make it appear that they are simple, but the reverse is the case. The labour involved is very great, and the difficulty soon becomes apparent when the work has fairly started. The sensitiveness of the eye to colour varies considerably, and this in itself makes observations hard. On some mornings, when coming fresh to the laboratory, the comparisons are readily made, but those made in the evenings after a day's work are often wild at first, and much more time has to be spent in perfecting them than may be supposed. Before any match can be considered worthy of recording, the eye has to be withdrawn from the light and to look into darkness for a minute at least, when a rapid glance will show if it needs alteration. If not correct, the slits have to be opened or closed, as may be required, and again a rest given to the eye. This procedure may be repeated several times before the match is considered satisfactory. The fatigue of the retina has a good deal to say to the difficulties encountered.

(XIII.) *Order of the Observations.*

It may be as well to record the order in which the observations were made. The first are preliminary, and are as follows :—

- (1.) The position of the spectrum in regard to the slit-holder is determined.
- (2.) The scales at the back and front of the slit-holder are compared.
- (3.) The lens with which the apertures of the slits are measured is adjusted.

The second are those taken for recorded observations :—

- (1.) The slits are placed in position.
- (2.) The matches are made.
- (3.) The luminosities of the light coming through the slits are measured and the apertures of the sectors noted.
- (4.) The widths of the slits are measured.

2 and 4 had to be repeated several times in each series of observations. I have already shown, in "Colour Measurement and Mixture," that a certain percentage of coloured light can be hidden in white without being perceived. In making a match with the white, each slit had to be opened in turn till it was evident that an excess

of coloured rays was issuing from it, when it was closed till the match was made. Again it was closed till it was evident that the colour was in defect, when it was opened till the match appeared correct. A mean of six observations was taken as being the most probable value of the mixture.

(XIV.) *The Red and Green Sensations Unmixed with Violet.*

To find the luminosities of the red and green sensations in the orange which matches a solution of bichromate of potash.

$$\begin{array}{rcc} & W & R & 288.5 \\ (\text{Bich}) + 16.5 & = & 45.5 + & 32. \end{array}$$

In the bichromate there is 4.5. Therefore

$$\begin{array}{rcc} & W & R & 288.5 \\ (\text{Or}) + 21 & = & 45.5 + & 32. \end{array}$$

$$\begin{array}{rcc} & RS & G \\ (\text{Or}) = 45.5 + & (32 - 21) \end{array}$$

$$\begin{array}{rcc} & RS & GS \\ = 45.5 + & 11. \end{array}$$

Therefore

$$(1) \quad \begin{array}{rcc} & RS & GS \\ 100 \text{ Or} = & 80.53 + & 19.47. \end{array}$$

Taking another example in detail, the slits being at 205 (R) and 270 (G),

$$\begin{array}{rcc} & W & R & 270 \\ (\text{Bi}) + 8.5 & = & 39.95 + & 24.5. \end{array}$$

$$\begin{array}{rcc} & W & W & R & 270 \\ (\text{Or}) + 4.5 + 8.5 & = & 39.95 + & 24.5. \end{array}$$

$$\begin{array}{rcc} & R & 270 & W. \\ (\text{Or}) = 39.95 + & 24.5 - & 13 \end{array}$$

$$\begin{array}{rcc} & R & 270' * \\ = 39.95 + & 11.5. \end{array}$$

$$(2) \quad \begin{array}{rcc} & R & 270' \\ 100 (\text{Or}) = & 77.6 + & 22.4. \end{array}$$

* 270' means 270 deprived of all violet.

It was found in forming the equations to match white that

$$\begin{array}{cccc} W & R & 288.5 & V \\ 100 = & 47.06 + & 51.79 + & 1.15. \end{array}$$

Also

$$\begin{array}{cccc} W & R & 270 & V \\ 100 = & 39.30 + & 59.15 + & 1.55. \end{array}$$

From which equation we find that

$$\begin{array}{cccc} 270 & R & 288.5 - V \\ 22.4 = & 2.94 + & 19.46. \end{array}$$

$$\begin{array}{cccc} R & 270 & R & R & 288.5 & V \\ 77.6 + & 22.4 = & 77.6 + & 2.94 + & 19.46. \end{array}$$

that is in (2).

Or

$$(3) \quad \begin{array}{ccc} & RS & GS \\ 100 (Or) = & 80.54 + & 19.46. \end{array}$$

Similarly it was found from slits placed at 205 and 283 that

$$(4) \quad \begin{array}{ccc} & RS & GS \\ 100 (Or) = & 80.50 + & 19.50. \end{array}$$

Other determinations gave a mean of

$$(5) \quad \begin{array}{ccc} & RS & GS \\ 100 (Or) = & 80.50 + & 19.50. \end{array}$$

The (Or) has SSN (.236), therefore

$$(236) \quad \begin{array}{ccc} & RS & GS \\ 100 = & 80.50 + & 19.50. \end{array}$$

(XV.) *Determination of the General Provisional Equation for White.*

Now the complementary colour to the violet at SSN 390 is SSN 245, and it was found that

$$\begin{array}{ccc} 236 & RS & 245 \\ 100 = & 35.86 + & 64.14. \end{array}$$

But

$$\begin{array}{ccc} 236 & RS & GS \\ 100 = & 80.50 + & 19.50. \end{array}$$

Therefore

$$(6) \quad \begin{array}{ccc} 245 & RS & GS \\ 100 = & 69.60 + & 30.40. \end{array}$$

Also it was found that

$$\begin{array}{rcc} \text{W} & 245 & 390 \\ 100 = & 98\cdot32 & + 1\cdot68. \end{array}$$

Therefore

$$(7) \quad \begin{array}{rcccc} \text{W} & \text{RS} & \text{GS} & \text{VS} \\ 100 = & 68\cdot42 & + 29\cdot90 & + 1\cdot68, \end{array}$$

which is the equation to white in terms of RS, GS, and the provisional violet sensation.

(XVI.) *Determination of the Sensation Values in the Orange, Yellow, and Green of the Spectrum.*

The slits placed at SSNs 220, 285, and 390.

$$\begin{array}{rcccc} & 220 & 285 & 390 & \text{W} \\ 48\cdot27 & + & 50\cdot52 & + & 1\cdot21 = 100. \end{array}$$

But as will be seen subsequently

$$\begin{array}{rccc} 285 & \text{RS} & \text{GS} & 390 \\ 100 = & 42\cdot71 & + & 56\cdot37 & + \cdot92. \end{array}$$

Therefore

$$\begin{array}{rccccc} 220 & \text{RS} & \text{GS} & 390 & 390 & \text{W} \\ 48\cdot27 & + & 21\cdot577 & + & 28\cdot472 & + & \cdot465 & + & 1\cdot21 = 100. \end{array}$$

Or

$$(8) \quad \begin{array}{rcc} 220 & \text{RS} & \text{GS} \\ 100 = & 97\cdot04 & + 2\cdot96. \end{array}$$

There is a small residuum of V equal to $\cdot01$ left, but as it is non-existent at this part of the spectrum it is added to the GS.

Slits at SSNs 228, 294, and 390.

$$\begin{array}{rccc} 228 & 294 & 390 \\ 59\cdot80 & + & 39\cdot86 & + & \cdot34 = 100. \end{array}$$

$$\begin{array}{rccc} 294 & \text{RS} & \text{GS} & 390 \\ 100 = & 37\cdot57 & + & 59\cdot08 & + & 3\cdot35. \end{array}$$

From which we get

$$(9) \quad \begin{array}{rcc} 228 & \text{RS} & \text{GS} \\ 100 = & 89\cdot37 & + 10\cdot63. \end{array}$$

The percentage composition of SSN 236 we have already found as

$$\begin{array}{rcc} 236 & \text{RS} & \text{GS} \\ 100 = & 80\cdot50 & + 19\cdot50. \end{array}$$

Slits at SSNs 240 and 205 to match 236.

$$\begin{array}{r} \text{But} \\ 236 \quad 205 \quad 240 \\ 100 = 22\cdot24 + 77\cdot76. \end{array}$$

$$\begin{array}{r} \text{Therefore} \\ 230 \\ 100 = 80\cdot50 + 19\cdot50. \end{array}$$

$$(10) \quad \begin{array}{r} 240 \quad \text{RS} \quad \text{GS} \\ 100 = 74\cdot92 + 25\cdot08. \end{array}$$

The percentage composition of 245 has already been found.

$$\begin{array}{r} 245 \quad \text{RS} \quad \text{GS} \\ 100 = 69\cdot60 + 30\cdot40. \end{array}$$

Slits placed at SSNs 205, 250 and 390.

$$\begin{array}{r} \text{But} \\ \text{RS} \quad 250 \quad 390 \quad \text{W} \\ 13\cdot78 + 84\cdot56 + 1\cdot66 = 100. \end{array}$$

$$\begin{array}{r} \text{Therefore} \\ \text{RS} \quad \text{GS} \quad 390 \\ 68\cdot42 + 29\cdot90 + 1\cdot68 = 100. \end{array}$$

$$(11) \quad \begin{array}{r} 250 \quad \text{RS} \quad \text{GS} \quad \text{V} \\ 100 = 64\cdot62 + 35\cdot36 + \cdot02. \end{array}$$

In a similar way the following percentages were found.

$$(12) \quad \begin{array}{r} 260 \quad \text{RS} \quad \text{GS} \quad \text{V} \\ 100 = 55\cdot68 + 44\cdot17 + \cdot15. \end{array}$$

$$(13) \quad \begin{array}{r} 270 \quad \text{RS} \quad \text{GS} \quad \text{V} \\ 100 = 49\cdot23 + 50\cdot55 + \cdot22. \end{array}$$

$$(14) \quad \begin{array}{r} 275 \quad \text{RS} \quad \text{GS} \quad \text{V} \\ 100 = 46\cdot75 + 52\cdot89 + \cdot36. \end{array}$$

$$(15) \quad \begin{array}{r} 280 \quad \text{RS} \quad \text{GS} \quad \text{V} \\ 100 = 44\cdot77 + 54\cdot94 + \cdot54. \end{array}$$

$$(16) \quad \begin{array}{r} 283 \quad \text{RS} \quad \text{GS} \quad \text{V} \\ 100 = 43\cdot63 + 55\cdot60 + \cdot77. \end{array}$$

$$(17) \quad \begin{array}{r} 285 \quad \text{RS} \quad \text{GS} \quad \text{V} \\ 100 = 42\cdot71 + 56\cdot37 + \cdot92. \end{array}$$

$$(18) \quad \begin{array}{r} 288\cdot5 \quad \text{RS} \quad \text{GS} \quad \text{V} \\ 100 = 41\cdot24 + 57\cdot74 + 1\cdot02. \end{array}$$

$$(19) \quad \begin{array}{cccc} 290 & \text{RS} & \text{GS} & \text{V} \\ 100 & = & 40\cdot53 + 58\cdot28 + & 1\cdot19. \end{array}$$

$$(20) \quad \begin{array}{cccc} 294 & \text{RS} & \text{GS} & \text{V} \\ 100 & = & 37\cdot57 + 59\cdot08 + & 3\cdot35. \end{array}$$

(XVII.) *Determination of the Sensation Values in the Blue-Green.*

The next determinations were made with two slits, as before described; one being at SSN 245 and the other in the blue of different hues, with the following results. The first one is shown in detail. Slits at SSNs 312 and 245.

The frame was moved .9 division of the scale towards the red, which was equivalent to placing the slits at SSNs 302.4 and 241.4 respectively, the back scale being .4 of the front scale.

Now the increase in red and consequent diminution in the green sensation at 241.4 is 4.54.

The proportion of RS to GS is therefore (see Equation (6) for 100)

$$\begin{array}{cccc} \text{RS} & \text{RS} & \text{GS} & \text{GS} \\ (69\cdot60 + 4\cdot54) & \text{to} & (30\cdot40 - 4\cdot54) & \text{or } 74\cdot14 \text{ to } 25\cdot86. \end{array}$$

The luminosity equation is

$$\begin{array}{ccc} 241\cdot4 & 208\cdot4 & \text{W.} \\ 87 & + & 13 = 100. \end{array}$$

From this we derive that

$$(21) \quad \begin{array}{cccc} 308\cdot4 & \text{RS} & \text{GS} & \text{V} \\ 100 & = & 30\cdot15 + 56\cdot85 + & 13. \end{array}$$

Slits at 245 and 320.

The slit-holder was moved 5 of the back scale, which was equivalent to moving each slit 2 units towards the red. The slits were, therefore, actually at 243 and 318.

The increase in red being 1.25 per cent. per unit of scale, at this point it became 72.1 per cent. and the green 27.9 per cent.

The equation is

$$\begin{array}{ccc} 243 & 318 & \text{W} \\ 92 & + & 8 = 100. \end{array}$$

Hence

$$(22) \quad \begin{array}{cccc} 318 & \text{RS} & \text{GS} & \text{V} \\ 100 & = & 26 + 53 + & 21. \end{array}$$

Similarly the following equations were found :—

$$(23) \quad \begin{array}{cccc} & 329 & \text{RS} & \text{GS} & \text{V} \\ 100 = & 18\cdot8 & + & 45\cdot3 & + 35\cdot9. \end{array}$$

$$(24) \quad \begin{array}{cccc} & 339\cdot6 & \text{RS} & \text{GS} & \text{V} \\ 100 = & 15 & + & 30 & + 55. \end{array}$$

$$(25) \quad \begin{array}{cccc} & 349\cdot75 & \text{RS} & \text{GS} & \text{V} \\ 100 = & 9\cdot7 & + & 19\cdot4 & + 70\cdot9. \end{array}$$

$$(26) \quad \begin{array}{cccc} & 359\cdot94 & \text{RS} & \text{GS} & \text{V} \\ 100 = & 4\cdot6 & + & 9\cdot4 & + 86. \end{array}$$

$$(27) \quad \begin{array}{cccc} & 370 & \text{RS} & \text{G} & \text{V} \\ 100 = & 0 & + & 3 & + 97. \end{array}$$

At 380 the violet was of the same hue as further in the spectrum.

This completes the observations made in the spectrum with the provisional violet sensation. It now remains to show how the composition of the violet was determined.

(XVIII.) *Determination of the Composition of the Violet.*

A slit was placed at SSN 205 and another at SSN 345, and mixture made to match a violet at SSN 400, to which white was added.

The equation was

$$\begin{array}{cccc} \text{B} & \text{R} & \text{V} & \text{W} \\ 33 + 15\cdot2 = & 21\cdot2 & + & 27, \end{array}$$

$$\begin{array}{ccc} \text{V} & \text{R} & \text{BS} \\ 21\cdot2 = & 15\cdot2 & + 6, \end{array}$$

or

$$(28) \quad \begin{array}{ccc} \text{V} & \text{RS} & \text{BS} \\ 100 = & 71\cdot7 & + 28\cdot3. \end{array}$$

Other equations made at 230, 235, 240, 250, gave the following :—

$$(29) \quad \begin{array}{ccc} \text{V} & \text{RS} & \text{BS} \\ 100 = & 70 & + 30. \end{array}$$

$$(30) \quad \begin{array}{ccc} \text{V} & \text{RS} & \text{BS} \\ 100 = & 72 & + 28. \end{array}$$

$$(31) \quad \begin{array}{ccc} \text{V} & \text{RS} & \text{BS} \\ 100 = & 74\cdot5 & + 25\cdot5. \end{array}$$

$$(32) \quad \begin{array}{ccc} \text{V} & \text{RS} & \text{BS} \\ 100 = & 73\cdot5 & + 26\cdot5. \end{array}$$

The adopted reading was

$$(33) \quad V \quad RS \quad BS \\ 100 = 72.5 + 27.5.$$

(XIX.) *Corrected Colour Sensations.*

TABLE I.

This equation was applied to the foregoing percentages of violet in the different colours. The next table shows the provisional and the correct percentages.

In this and the following tables the former are shown in italics.

SSN.	Standard scale number.	Provisional sensations.			Corrected sensations.		
		Red.	Green.	Violet.	Red.	Green.	Blue.
205	59.83	<i>100</i>	<i>0</i>	<i>0</i>	100	0	0
215	57.07	<i>100</i>	<i>0</i>	<i>0</i>	100	0	0
220	55.70	<i>97.04</i>	<i>2.96</i>	<i>0</i>	97.04	2.96	0
228	53.48	<i>89.37</i>	<i>10.63</i>	<i>0</i>	89.37	10.63	0
236	51.27	<i>80.50</i>	<i>19.50</i>	<i>0</i>	80.50	19.50	0
240	50.17	<i>74.92</i>	<i>25.08</i>	<i>..</i>	74.92	25.08	<i>..</i>
245	48.80	<i>69.60</i>	<i>30.40</i>	<i>..</i>	69.60	30.40	<i>..</i>
250	47.42	<i>64.62</i>	<i>35.36</i>	<i>0.02</i>	64.63	35.36	0.01
260	44.67	<i>55.68</i>	<i>44.17</i>	<i>0.15</i>	55.79	44.17	0.04
270	41.92	<i>49.23</i>	<i>50.55</i>	<i>0.22</i>	49.38	50.55	0.07
275	40.55	<i>46.75</i>	<i>52.89</i>	<i>0.36</i>	47.01	52.89	0.10
280	39.17	<i>44.77</i>	<i>54.69</i>	<i>0.54</i>	45.16	54.69	0.15
283	38.35	<i>43.63</i>	<i>55.60</i>	<i>0.77</i>	44.18	55.60	0.22
285	37.80	<i>42.71</i>	<i>56.37</i>	<i>0.92</i>	43.37	56.37	0.26
288.5	36.83	<i>41.24</i>	<i>57.74</i>	<i>1.02</i>	41.97	57.74	0.29
290	36.42	<i>40.53</i>	<i>58.28</i>	<i>1.19</i>	41.39	58.28	0.33
294	35.32	<i>37.57</i>	<i>59.08</i>	<i>3.35</i>	40.00	59.08	1.92
308.4	31.37	<i>30.15</i>	<i>56.85</i>	<i>13.00</i>	39.57	56.85	3.58
315	28.73	<i>26.00</i>	<i>53.00</i>	<i>21.00</i>	41.22	53.00	5.78
329	25.71	<i>18.20</i>	<i>45.30</i>	<i>35.90</i>	44.83	45.30	9.87
339.6	22.78	<i>15.00</i>	<i>30.00</i>	<i>55.00</i>	54.87	30.00	15.13
349.75	20.00	<i>9.70</i>	<i>19.40</i>	<i>70.90</i>	61.10	19.40	19.50
359.9	17.17	<i>4.60</i>	<i>9.40</i>	<i>86.00</i>	66.95	9.4	23.65
370	14.42	<i>0</i>	<i>3</i>	<i>97.00</i>	70.32	3.0	26.68

Both sets of ordinates were drawn from the preceding table, and freehand curves drawn through them. (The standard scale is the same as in 'Colour Photometry,' Part III.) The results are shown in fig. 3. It will be noticed that, had the provisionally-employed violet sensation been correct, the percentage curves are very fairly regular, and altogether what would have been expected, but that in the true sensation curves the red sensation takes a form which is curious, and one which, from any theoretical considerations, would not be prophesied as probable. In every investigation, whether of colour fields or otherwise, the red sensation seems to be but little connected with the other two.

(XX.) *Sub-division of Luminosity into Sensations.*

Having ascertained the percentage composition in sensation luminosity of all the spectrum, the luminosity curve of any known spectrum can be sub-divided into

Fig. 3.

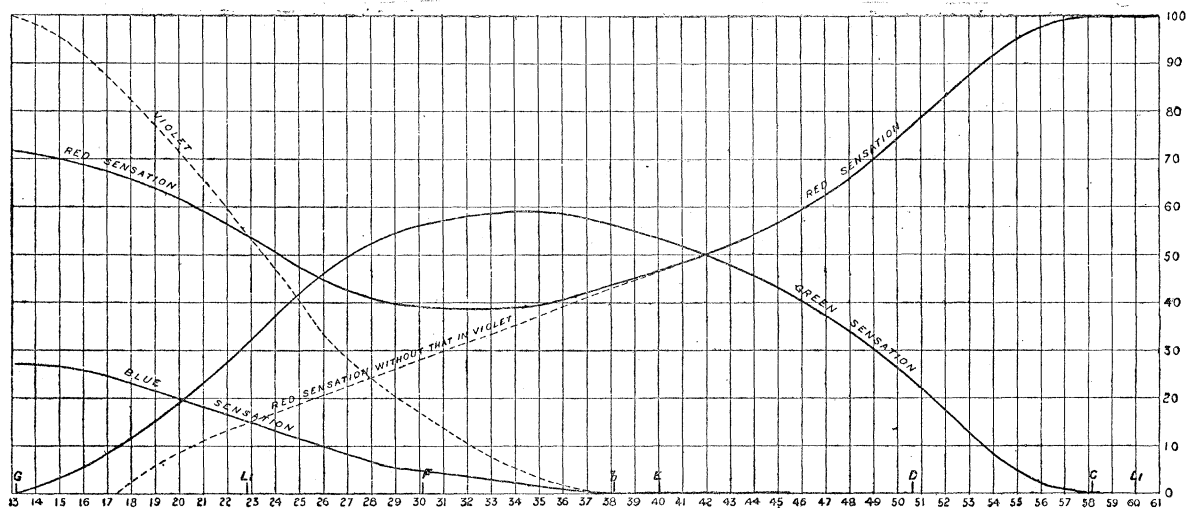

Percentage of colour sensations as luminosity in the prismatic spectrum colours.

Fig. 4.

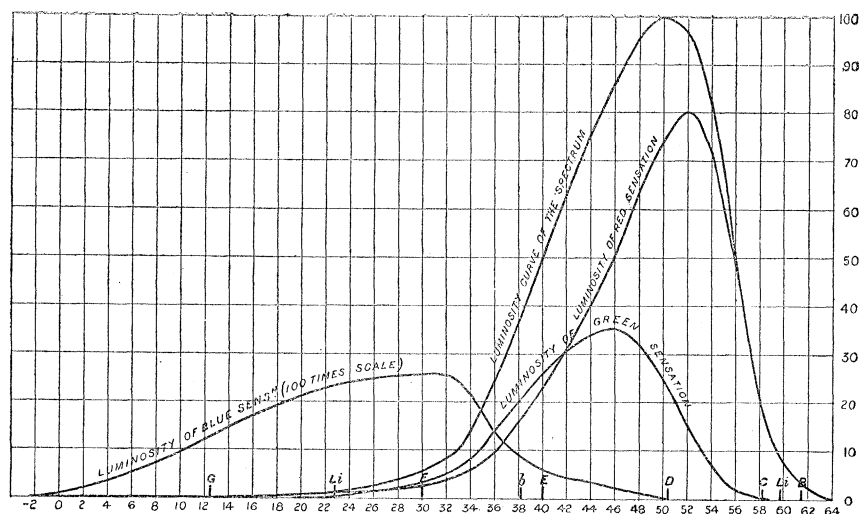

Sensation-luminosities in the spectrum of the light of the crater of the positive pole of the arc light as seen with the centre of the retina.

sensation-luminosities. This is done in the next table. Columns X., XI., XII., XIII., XIV., XV. and XVI. give the sensation-luminosity curves derived from the total luminosity curve of the spectrum of the crater of the positive pole of the arc

electric light, the ordinates for which are given in 'Colour Photometry,' Part III. The graphic results are shown in fig. 4. In this figure the blue sensation curve ordinates are on a scale 100 times larger than those of the red and green sensations. The luminosity of this blue sensation is really very small, and except for the hue would be negligible.

The areas of the sensation curves in this figure, or of one constructed with the RS, GS, and VS, should, supposing the white light to be the same as that used in the observations, be proportional to the constants in the colour equations for white light. The areas of the RS, GS, and VS curves are closely 1102, 529, and 247 on an empiric scale, and these numbers, converted into percentages, give

$$\begin{array}{cccc} \text{RS} & \text{GS} & \text{V} & \text{W} \\ 66\cdot55 & + & 31\cdot96 & + & 1\cdot49 & = & 100. \end{array}$$

The equation employed is

$$\begin{array}{cccc} \text{RS} & \text{GS} & \text{V} & \text{W} \\ 68\cdot42 & + & 29\cdot90 & + & 1\cdot68 & = & 100. \end{array}$$

Owing to the colour of the glass interposed in the beam, and to the slightly different angular dimension on the retina of the images in the measurements on the two occasions, this small discrepancy is fully accounted for. To see whether experiments bear out this deduction, a measure was made under the conditions which were present when the curves in 'Colour Photometry,' Part III., were made, and it came out as follows—

$$\begin{array}{cccc} \text{RS} & \text{GS} & \text{V} & \text{W} \\ 66\cdot20 & + & 32\cdot28 & + & 1\cdot52 & = & 100. \end{array}$$

This is sufficiently close to indicate that the measurements made are fairly exact.

TABLE II.—Table showing Results of Applying Table I. to the Luminosity Curve of the Spectrum as Measured on the Yellow Spot of the Retina.

I.	II.	III.	IV.		V.		VI.		VII.			VIII.		IX.	X.	XI.		XII.		XIII.		XIV.		XV.		XVI.		XVII.	XVIII.	XIX.
			Scale number of spectrum.	SSN.	λ .	Percentages of luminosity of	Percentages of luminosity of	Final percentages of	Luminosity of spectrum colours.	RS.	GS.	VS.	RS.			GS.	BS.	RS.	GS.	BS.	RS.	GS.	BS.	RS.	GS.	BS.	RS.			
64	...	7217	100	0	0	100	0	0	0	0	0	0	0	0.5	0	0.5	0	0	0	0	0	0.5		
63	...	7082	100	0	0	100	0	0	0	0	0	0	0	1	1	1	0	0	0	0	0	1		
62	...	6957	100	0	0	100	0	0	0	0	0	0	0	2	2	2	0	0	0	0	0	2		
61	198.73	6839	100	0	0	100	0	0	0	0	0	0	0	4	4	4	0	0	0	0	0	4		
60	204.36	6728	100	0	0	100	0	0	0	0	0	0	0	7	7	7	0	0	0	0	0	7		
59	208.00	6621	100	0	0	100	0	0	0	0	0	0	0	12.5	12.5	12.5	0	0	0	0	0	12.5		
58	211.64	6520	99.5	0.5	0	99.5	0	0	0	0	0	0	0	21	20.89	20.89	0	0	0	0	0	20.89		
57	215.28	6423	99	1	0	99	1	0	0	0	0	0	0	33	32.67	32.67	0	0	0	0	0	32.67		
56	218.92	6330	98	2	0	98	2	0	0	0	0	0	0	50	49.00	49.00	0	0	0	0	0	49.00		
55	222.55	6242	95.5	4.5	0	95.5	4.5	0	0	0	0	0	0	65	62.05	62.05	0	0	0	0	0	62.05		
54	226.19	6152	92	8.0	0	92	8.0	0	0	0	0	0	0	80	73.6	73.6	0	0	0	0	0	73.6		
53	229.73	6074	88	12.0	0	88	12.0	0	0	0	0	0	0	90	79.2	79.2	0	0	0	0	0	79.2		
52	233.36	5996	83	17	0	83	17	0	0	0	0	0	0	96	79.58	79.58	0	0	0	0	0	79.58		
51	237.00	5919	79	21	0	79	21	0	0	0	0	0	0	99	78.22	78.22	0	0	0	0	0	78.22		
50	240.64	5850	74	26	0	74	26	0	0	0	0	0	0	100	74.00	74.00	0	0	0	0	0	74.00		
49	244.27	5783	70	30	0	70	30	0	0	0	0	0	0	99	69.30	69.30	0	0	0	0	0	69.30		
48	247.91	5720	66.5	33.5	0.03	66.51	33.5	0.008	0.03	0.005	66.51	33.5	0.008	97	64.50	64.50	0	0	0	0	0	64.50		
47	251.55	5658	62.7	37.2	0.05	62.73	37.2	0.013	0.05	0.01	62.73	37.2	0.013	92.5	58.00	58.00	0	0	0	0	0	58.00		
46	255.18	5596	59.2	40.7	0.08	59.26	40.7	0.022	0.08	0.01	59.26	40.7	0.022	87	51.50	51.50	0	0	0	0	0	51.50		
45	258.83	5538	56.2	43	0.11	56.28	43.0	0.03	0.11	0.01	56.28	43.0	0.03	81	45.52	45.52	0	0	0	0	0	45.52		
44	262.46	5481	53.7	46.2	0.15	53.81	46.2	0.04	0.15	0.01	53.81	46.2	0.04	75	40.27	40.27	0	0	0	0	0	40.27		
43	266.10	5427	51.2	48.6	0.20	51.54	48.6	0.06	0.20	0.01	51.54	48.6	0.06	69	35.33	35.33	0	0	0	0	0	35.33		
42	269.73	5373	49.5	50.3	0.26	49.69	50.3	0.07	0.26	0.01	49.69	50.3	0.07	62.5	30.94	30.94	0	0	0	0	0	30.94		
41	273.37	5321	47.7	52.0	0.34	48.50	52.0	0.095	0.34	0.01	48.50	52.0	0.095	57	27.19	27.19	0	0	0	0	0	27.19		
40	277.01	5270	46.0	53.5	0.46	46.34	53.5	0.12	0.46	0.01	46.34	53.5	0.12	50	23.00	23.00	0	0	0	0	0	23.00		
39	280.64	5221	44.5	54.9	0.60	45.44	54.9	0.165	0.60	0.01	45.44	54.9	0.165	42.5	18.91	18.91	0	0	0	0	0	18.91		
38	284.28	5172	43.38	56.4	0.80	43.38	56.4	0.22	0.80	0.01	43.38	56.4	0.22	36.0	15.41	15.41	0	0	0	0	0	15.41		
37	287.92	5128	41.2	57.7	1.1	42.00	57.7	0.30	1.1	0.01	42.00	57.7	0.30	29.5	12.15	12.15	0	0	0	0	0	12.15		
36	291.55	5085	39.3	58.9	1.8	40.6	58.9	0.50	1.8	0.01	40.6	58.9	0.50	24	9.43	9.43	0	0	0	0	0	9.43		

TABLE II. (continued).—Table showing Results of Applying Table I. to the Luminosity Curve of the Spectrum as measured on the Yellow Spot of the Retina.

I.	Scale number of spectrum.	II.	SSN.	III.	λ.	IV.			V.			VI.			VII.			VIII.			IX.			X.	XI.			XII.			XIII.			XIV.			XV.			XVI.			XVII.			XVIII.			XIX.		
						RS.	GS.	VS.	RS.	GS.	VS.	RS.	GS.	VS.	RS.	GS.	VS.	RS.	GS.	VS.	RS.	GS.	VS.		RS.	GS.	VS.	RS.	GS.	VS.	RS.	GS.	VS.	RS.	GS.	VS.	RS.	GS.	VS.	RS.	GS.	VS.									
35	295.19		37.0	504.3	3.6	59.0	39.6	59.0	1.00	18.4	6.81	11.06	0.662	7.28	11.04	.183	7.28	23.44	7.28	23.44	30.2																														
34	298.83		35.0	500.2	5.5	59.0	39	59.0	1.5	14.2	4.97	8.38	0.781	5.53	8.38	.215	5.53	17.54	5.53	17.54	35.47																														
33	302.47		33.0	496.3	7.5	58.5	39.4	52.5	2.1	10.5	3.46	6.15	0.892	4.10	6.15	.245	4.10	13.04	4.10	13.04	40.40																														
32	306.10		31.0	492.4	11	58	39	58.0	3.0	8.5	2.63	4.93	0.935	3.30	4.93	.257	3.30	10.45	3.30	10.45	42.40																														
30	313.38		27.0	484.8	17	56.0	39.3	56.0	4.7	5.7	1.48	3.08	0.969	2.18	3.08	.268	2.18	6.53	2.18	6.53	44.00																														
28	320.65		23.5	477.6	24	52.5	40.9	53.5	6.6	4	.940	2.10	0.960	1.63	2.10	.265	1.63	4.45	1.63	4.45	43.23																														
26	327.92		19.7	470.7	33.5	46.8	44.0	46.8	9.2	2.8	.55	1.31	0.938	1.23	1.31	.257	1.23	2.78	1.23	2.78	42.40																														
24	335.19		16.0	463.9	48	37	50.3	37	12.9	1.9	.35	.60	0.893	.99	.60	.245	.99	1.23	.99	1.23	40.43																														
22	342.47		12.5	457.8	60	27.5	56.0	27.5	16.5	1.4	.17	.29	0.840	.88	.29	.233	.88	.63	.88	.63	38.44																														
20	349.73		9.5	451.7	71.5	19.0	61.5	19.0	19.5	1.1	.10	.22	0.786	.67	.22	.213	.67	.47	.67	.47	35.14																														
18	357.00		6	445.9	82.5	11.5	66	11.5	22.5	.86	.05	.11	0.761	.56	.11	.193	.56	.23	.56	.23	32.21																														
16	364.25		2.5	440.4	92.5	5.0	69.5	5.0	25.5	.70	.01	.05	0.647	.47	.05	.178	.47	.10	.47	.10	29.37																														
14	371.50		0	434.9	98	2.0	71	2.0	27.0	.56	0	.01	0.548	.39	.01	.155	.39	.02	.39	.02	25.57																														
12	378.75		0	429.6	99.5	0.5	72.1	0.5	27.4	.45	0	0	0.445	.32	0	.127	.32	0	.32	0	20.95																														
10	386.00		0	424.5	100	0	72.5	0	27.5	.34	0	0	0.34	.25	0	.092	.25	0	.25	0	15.1																														
8	393.27		0	419.7	100	0	72.5	0	27.5	.26	0	0	0.26	.19	0	.075	.19	0	.19	0	8.5																														
6	400.52		0	415.1	100	0	72.5	0	27.5	.18	0	0	0.18	.13	0	.050	.13	0	.13	0	8.5																														
4	407.25		0	410.6	100	0	72.5	0	27.5	.14	0	0	0.14	.10	0	.039	.10	0	.10	0	6.6																														
2	...		0	406.0	100	0	72.5	0	27.5	.10	0	0	0.10	.07	0	.023	.07	0	.07	0	4.4																														

(XXI.) *Curves showing Equal Ordinates of Red, Green, and Blue Sensations to give White Light.*

The equation derived from the foregoing areas being taken as correct, when the blue sensation replaces the violet, the final equation becomes

$$\begin{array}{cccc} \text{RS} & \text{GS} & \text{BS} & \text{W} \\ 67\cdot63 & + & 31\cdot96 & + & \cdot41 & = & 100, \end{array}$$

and we can find the curves which will have ordinates on such a scale that, when equal, they give white. Taking the red curve as the standard, we must multiply the GS ordinates by $\frac{67\cdot63}{31\cdot96}$, or 2.12, to make the areas of the two equal. When equal, the desired result is obtained as far as the green sensation is concerned. The BS ordinates must be multiplied by $\frac{67\cdot63}{\cdot41}$, or 165, to obtain the result for the third curve. These new ordinates are shown in Columns XVIII. and XIX., Table II., and these, with Column XVII., are shown graphically in fig. 5.

Fig. 5.

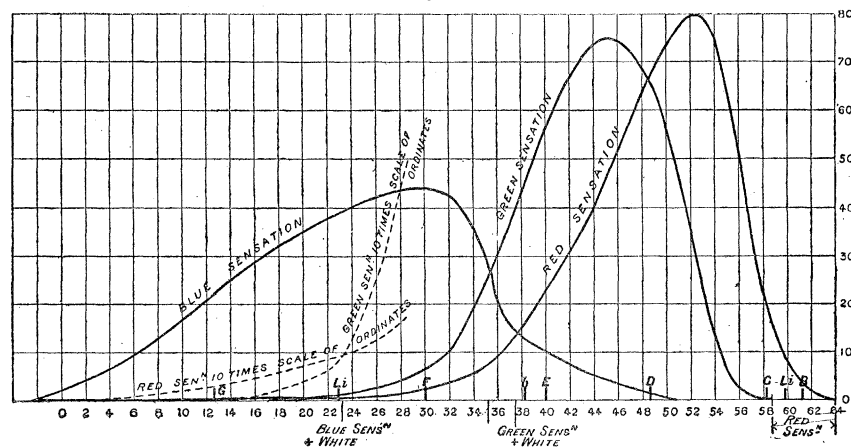

Sensation curves (prismatic spectrum) in which equal heights of ordinates form white.

From these curves can be seen at a glance the positions that A and D, fig. 1, occupy, and they show also those parts of the spectrum where the green and blue sensations are seen, unmixed with any other sensation except white. These positions of A and D we find to be about Scale Nos. 37.3 and 35.2, which are λ 5120 and 5060 respectively. The purest green sensation is felt at the former Scale Number, and the purest blue sensation is at Scale No. 23.2, or close to the blue lithium line, which is at Scale No. 22.8. As before said, the light of the crater is of that "whiteness" which closely matches the white outside the colour fields; hence it may be surmised that at these two points we have the nearest approach to the true green and blue sensations.

(XXII.) *Confirmation of the Observations by Colour-blind Persons.*

In confirmation of the positions of A and D, fig. 1, as stated before, complete red- and green-blind eyes were called in to make observations. A totally green-blind person gave the following readings for that position in the spectrum where white was matched. The Scale Numbers used are those of the diagram.

The white was placed alongside the spectrum colours, and the slit through which the colour issued was gradually moved from the red towards the neutral point. The same procedure was adopted in moving from the blue towards the same point.

The readings were

From the red.				From the blue.		
38·5,	37·5,	38,	37·1	36·8,	37·1,	37·5.

The mean of these readings is 37·7 as the neutral point of the green-blind. The difference is only ·2 of the scale. A look at the curve will show that there is likely to be greater variation when moving the slit from the red, as the curve is there less steep. A mean of the readings "from the blue" gives 37·1, the position fixed by the preliminary trials, and which answers to SSN 288·5.

Two red-blind persons marked the point in the spectrum where the colour matched white. One read 34·2, 35, 35·4, or a mean of 35·1; the other read 35·2, 35, 35·6, 35·8, or a mean of 35·4. The mean of the two means is 35·2.

From the coincidence of the areas with the colour equations, and from the position of neutral points of the colour-blind with the points where the curves met, we may conclude that the observations are correct within the limits of the errors of observation.

It may be stated that the nearest approaches to the colour sensations in pigments are: Vermilion, to which a little blue has been added; emerald green and true ultramarine, to which a slight trace of red has been added. GREVILLE'S cyanine blue is not far from the colour. All are slightly paler, however, and in using them as colour discs this paleness must be allowed for.

(XXIII.) *The Observations applied to the Normal Spectrum of the Electric Arc Light.*

Before proceeding further, I have thought that it would be of interest to show the colour sensations of a normal spectrum. The compression of the red in the prismatic spectrum and the extension of the blue does not enable a comparison to be easily made between the sensation curves of this spectrum and the results obtained by KÆNIC, which are based on the normal spectrum.

The following table is calculated from observations made with a grating spectrum in 1891. The grating was ruled on speculum metal, and had about 14,000 lines to the inch.

I. λ .	II. III. IV. Percentage luminosity.			V. Lumi- nosity of spec- trum.	VI. VII. VIII. Sub-division of spectrum luminosity into luminosities of			IX. X. XI. Equal ordinates to give white.		
	RS.	GS.	BS.		RS.	GS.	BS.	RS.	GS.	BS.
7100	100	0	0	0.5	0.5	0.5
7000	100	0	0	0.9	0.9	0.9
6900	100	0	0	1.6	1.6	1.6
6800	100	0	0	3.2	3.2	3.2
6700	100	0	0	6.0	6.0	6.0
6600	99.8	0.2	0	10.0	9.9	0.1	...	9.9	0.22	...
6500	99	1.0	0	17.0	16.8	0.2	...	16.8	0.44	...
6400	98	2.0	0	26.0	25.48	0.52	...	25.48	1.13	...
6300	97	3.0	0	41	39.77	1.23	...	39.77	2.67	...
6200	94	6.0	0	59	55.46	3.54	...	55.46	7.68	...
6100	89.5	10.5	0	75	67.13	7.87	...	67.13	17.08	...
6000	83.3	16.7	0	85	70.81	14.19	...	70.81	30.79	...
5900	77.5	22.5	0	93	72.08	20.92	...	72.08	45.39	...
5800	71.3	28.7	0.005	99	70.38	28.42	.005	70.38	61.67	0.7
5700	65.3	35.0	0.01	100	65.00	35.00	.01	65.00	75.95	1.4
5600	59.3	40.5	0.023	95	56.52	38.46	.02	56.52	83.45	2.9
5500	54.3	45.7	0.040	89	48.33	40.64	.035	48.33	90.19	4.9
5400	49.7	50.2	0.065	80	39.76	40.16	.052	39.76	87.15	7.38
5300	47.2	52.7	0.11	70	33.04	36.58	.077	33.04	79.37	10.93
5200	53.6	56.2	0.18	56	24.00	29.90	.099	24.00	64.88	14.10
5100	41.2	58.4	0.42	35	14.42	20.43	.147	14.42	44.33	20.87
5000	39.3	59.0	1.6	18	7.09	10.61	.300	7.09	23.02	40.89
4900	39.0	57.5	3.5	11	4.48	6.50	.385	4.48	14.10	54.60
4800	40.0	54.0	6.0	7.5	3.00	4.05	.456	3.00	8.79	64.75
4700	45.0	44.8	10.2	5.0	2.25	2.24	.510	2.25	4.88	71.00
4600	54.5	30.0	15.5	3.5	1.90	1.06	.542	1.90	2.30	76.9
4500	63.5	16.0	20.5	2.7	1.71	0.44	.553	1.71	0.95	78.5
4400	69.8	4.5	25.7	2.1	1.47	0.09	.540	1.47	0.20	76.68
4300	72.5	0	27.5	1.7	1.23	0	.470	1.23	0	66.74
4200	72.5	0	27.5	1.3	.94	0	.357	.94	0	50.69
4100	72.5	0	27.5	1.0	.72	0	.275	.72	0	39.05
4000	72.5	0	27.5	.75	.54	0	.206	.54	0	29.25
3900	72.5	0	27.5	.50	.36	0	.137	.36	0	19.45
3800	72.5	0	27.5	.25	.18	0	.068	.18	0	9.22

Column I. shows the wave-lengths; Columns II., III., and IV. the percentage luminosity of the sensations (see fig. 6); Column V. the luminosity; Columns VI., VII., and VIII. the luminosity of the sensations in the normal spectrum. The approximate areas of the three curves shown in Columns VI., VII., and VIII., and graphically in fig. 7, are 747.6, 344.3, and 5.3 for the RS, GS, and BS respectively, and the equation for white is

$$\text{RS} \quad \text{GS} \quad \text{BS} \quad \text{W}$$

$$68.14 + 31.38 + .48 = 100.$$

Columns VII. and VIII. have to be multiplied by $\frac{68.14}{31.32}$ and $\frac{68.14}{.48}$, or 2.17 and 142

respectively, to give equal areas with the RS area in Column VI. Column IX. is Column VI. repeated, and Columns X. and XI. show the curves for the GS and BS when of equal areas, hence the ordinates, when equal, give white. These last curves are shown in fig. 8. The above equation is not very different from that obtained

Fig. 6.

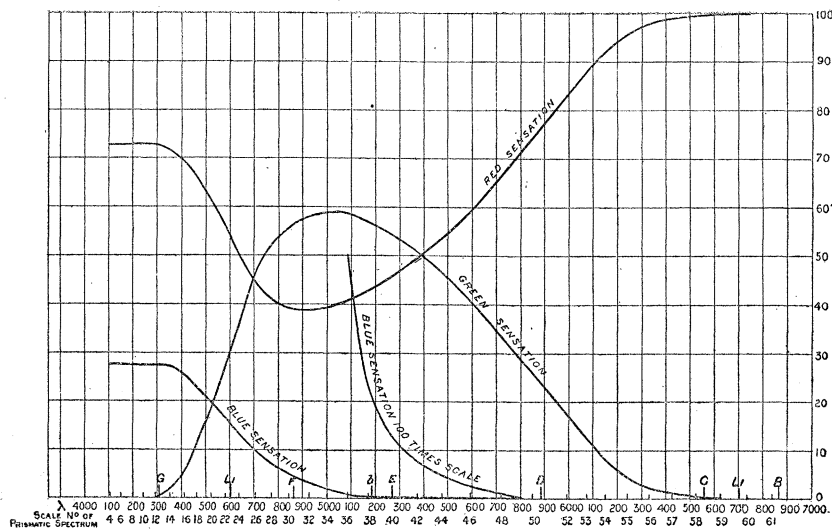

Percentage composition in sensations of the spectrum colours, normal spectrum.

Fig. 7.

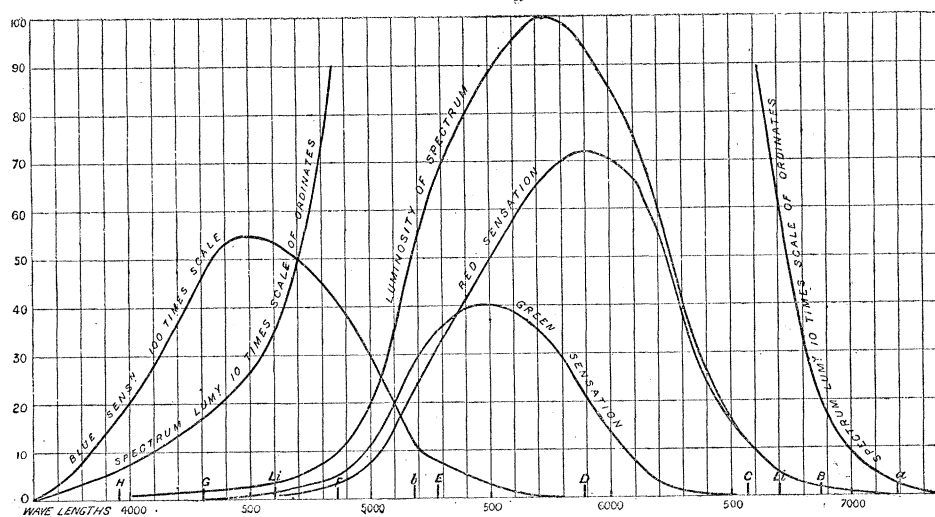

Normal luminosity curve in wave-lengths (electric light). Divided into sensation luminosities.

from the prismatic spectrum of the same light. Any difference is caused in all probability by the colour of the light reflected by the grating, together with that caused by the necessary error of observation.

A comparison of the curves in figs. 5 and 8 shows what an effect the compression and extension of the red and blue of the spectrum has on the shape and appearance

of the curves, and how they approach in some respects those of KÆNIG'S, of which fig. 9 is a rough representation taken from one of his diagrams. There is a marked difference, however, in the amount of red shown as existing in the violet. Whatever source of light is taken as the standard the same proportion will exist.

Fig. 8

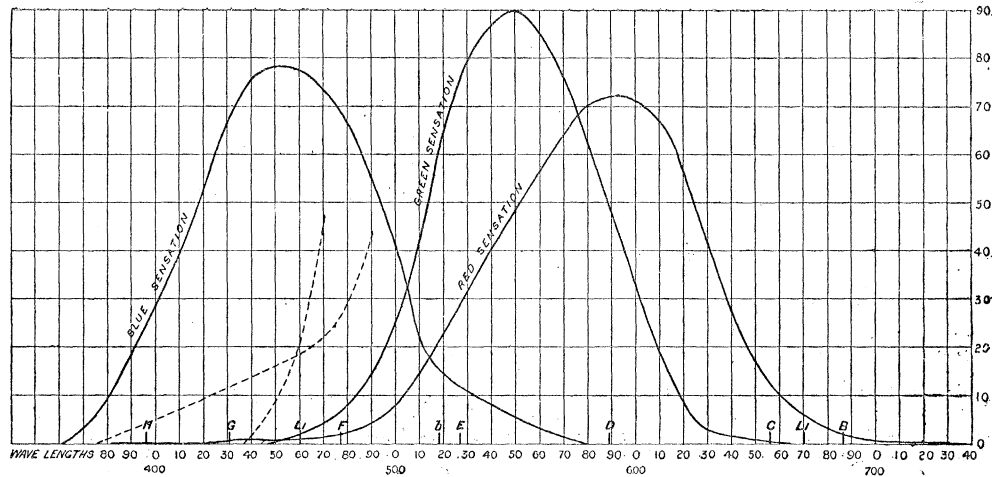

Sensation curves (normal spectrum) in which equal heights of ordinates form white (electric light crater).

Fig. 9.

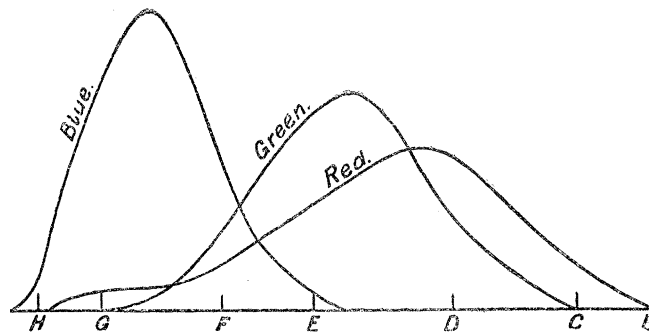

(XXIV.) *Observation applied to the Solar Spectrum.*

One more example may be given. The sun's spectrum in the month of September, at noon, was measured several years ago, and this has been divided up into luminosities. It is very similar in characteristics to the electric light spectrum. The equation to the white light derived from the areas is

$$\begin{array}{cccc} \text{RS} & \text{GS} & \text{BS} & \text{W} \\ 65\cdot73 & + & 33\cdot83 & + \cdot44 = 100. \end{array}$$

The green sensation is more stimulated by this light than it is in the electric light, whilst curiously enough the blue sensation appears to be very much the same (fig. 10).

To reduce the curves to equal areas the green sensation has to be multiplied by 1.94 and the blue by 1.49. These are given in Columns VI., VII., and VIII. of the table and are graphically shown in fig. 11.

Fig. 10.

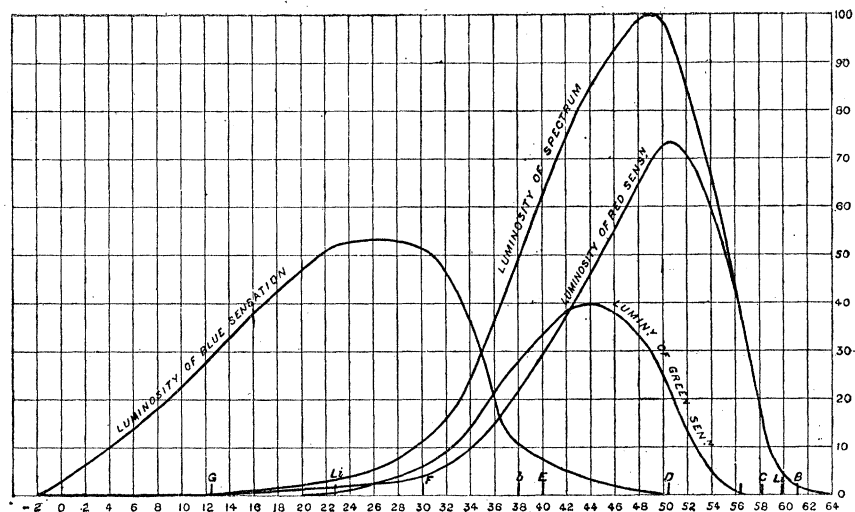

Sensation luminosities in sunlight of noon in September.

Fig. 11.

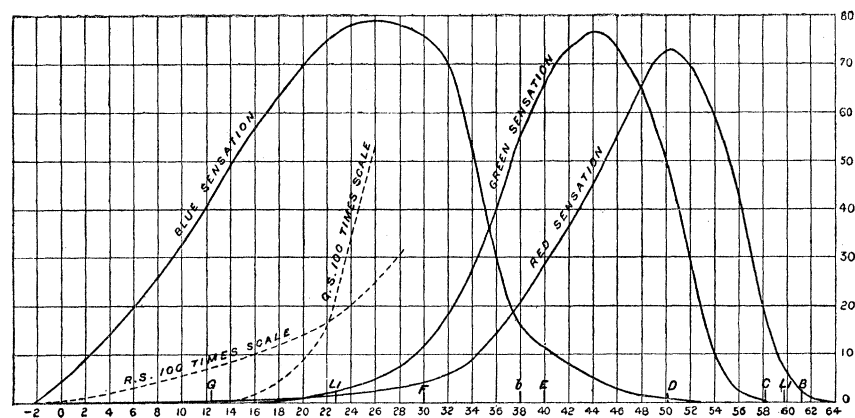

Sensation curves (prismatic spectrum) in which equal heights of ordinates form white (sun light).

SENSATION Curves in Sun's Spectrum.

I. Scale number.	II. Luminosity.	III. IV. V. Percentage composition.			VI. VII. VIII. Curves of equal areas.		
		RS.	GS.	BS.	RS.	GS.	BS.
		64	0	0	0
63	0.5	0.5	0.5
62	0.74	0.74	0.74
61	2.5	2.5	2.5
60	4.5	4.5	4.5
59	9.0	9.0	9.0
58	19.0	18.9	0.1	...	18.9	0.19	...
57	32.0	31.68	0.32	...	31.68	0.62	...
56	43.0	42.14	0.86	...	42.14	1.67	...
55	55	52.52	2.48	...	52.52	4.81	...
54	64	58.88	5.12	...	58.88	9.93	...
53	75	66.00	9.00	...	66.00	17.46	...
52	85	70.55	14.45	...	70.55	28.03	...
51	93	73.47	19.53	...	73.47	37.89	...
50	98	72.62	25.38	.001	72.62	48.24	0.148
49	100	70.00	30.00	.004	70.00	58.20	0.592
48	98.5	65.42	33.00	.008	65.42	64.02	1.184
47	95.5	59.94	35.55	.012	59.94	68.97	1.776
46	93.5	55.40	38.08	.021	55.40	73.87	3.108
45	90	50.34	39.63	.027	50.34	76.88	3.996
44	85	45.74	39.23	.034	45.74	76.10	5.032
43	80.2	41.17	38.98	.048	41.17	75.62	7.104
42	75.5	37.31	38.14	.053	37.31	73.99	7.844
41	69.5	33.32	36.11	.066	33.32	70.05	9.768
40	63.0	28.52	33.73	.075	28.52	65.44	11.100
39	56.5	25.69	31.02	.093	25.69	60.18	13.764
38	50	21.69	28.20	.110	21.69	54.71	16.280
37	43.5	18.27	25.10	.130	18.27	48.69	19.244
36	36.5	14.82	21.03	.200	14.82	40.80	29.600
35	30.0	11.88	17.82	.300	11.88	34.57	44.40
34	24	9.36	14.28	.360	9.36	27.70	53.28
33	19	7.48	11.12	.399	7.48	21.57	59.05
32	16	6.24	9.28	.480	6.24	18.00	71.04
30	11	4.32	6.16	.517	4.32	11.95	76.52
28	7.8	3.19	4.08	.529	3.19	7.91	78.29
26	5.85	2.57	2.75	.533	2.57	5.33	78.88
24	4.1	2.06	1.51	.529	2.06	2.93	78.29
22	3.1	1.73	0.85	.511	1.73	1.64	75.63
20	2.3	1.41	0.42	.470	1.41	0.81	69.56
18	1.9	1.25	0.22	.427	1.25	0.43	63.20
16	1.5	1.04	0.08	.382	1.04	0.15	56.54
14	1.24	0.88	0.03	.335	0.88	0.08	49.58
12	1.03	0.73	0.02	.282	0.73	0.04	41.74
10	0.80	0.58	0	.220	0.58	0	32.56
8	0.66	0.48	0	.180	0.48	0	26.60
6	0.51	0.37	0	.140	0.37	0	20.70
4	0.36	0.26	0	.100	0.26	0	14.80
2	0.23	0.16	0	.070	0.16	0	10.40

In fig. 10 it will be noticed that A and D of fig. 1 are somewhat closer together, and that the place where the blue sensation exists mixed with white alone, is again close to the blue lithium line. The blue sensation curve is also somewhat higher.

Confirmatory of these curves are the luminosity curves given for the red blind in 'Colour Photometry,' Part III. If the curves there given be reduced to a little more than one-half the scale of ordinates, they will be found to closely correspond to those of fig. 4. It must be remembered that to them the red luminosity is non-existent throughout the spectrum, hence the luminosity of the violet end is much diminished. For this reason the luminosity curves were made on too high a scale when drawn for that paper, and they should be corrected accordingly. It need not follow from this investigation that the colour-blind see less light than those having the three full sensations, though the "extinction" readings given in that same paper seem to indicate that such is the case. A further investigation into this is in hand, and for the present the question must be left an open one.

I have to thank my assistant, Mr. WALTER BRADFIELD, for the aid he has given me in this investigation. The actual observations recorded were made by myself, but all preparatory work was done by him.